

# Light SuperWale™ Data Sheet

## (Part Number TQ440)

Refer to the SuperLoc™ Design/Installation Manual for Comprehensive Information

\*Wale & Retaining Wall System  
(US Patent #6,893,191 B2/May 17, 2005)

### Physical Properties

Depth of Section	4.00 in. 101.6 mm
Width of Section	4.00 in. 101.6 mm
Minor Moment of Inertia	8.750 in <sup>4</sup> 3.64E+06 mm <sup>4</sup>
Minor Section Modulus	4.375 in <sup>3</sup> 2.35E+05 mm <sup>3</sup>
Weight	2.96 lbs./ft. 4.40 kg/m
Area of Web	2.00 in <sup>2</sup> 1,290 mm <sup>2</sup>
Ultimate Waler Crush Strength (with system washer)	9,900 lbs. 4,491 kg.

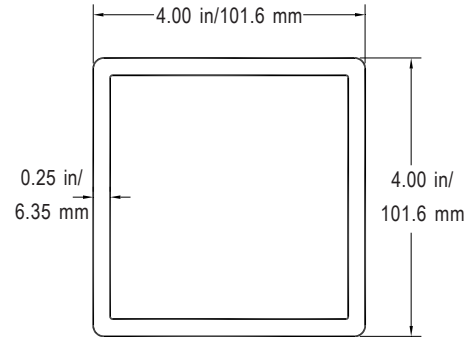

Note: Values are not factored, an appropriate safety factor must be applied  
Design values based on SuperLoc™ Hardware only.

Mechanical Properties	Test Method		Average Values Imperial	Average Values Metric
Full Section Modulus of Elasticity	***	Lab	3.20E+06 psi	22,063 MPa
Full Section Modulus of Rigidity	***	Lab	420,000 psi	2,896 MPa
Ultimate Shear Capacity	***	Lab/Calculated	10,000 lbs.	4,536 kg.
Ultimate Moment Capacity	***	Lab/Calculated	6,748 ft.-lbs.	8,783 N-m
Tensile Strength LW	***	ASTM D638	33,000 psi	228 MPa
Compression Strength LW	***	ASTM D695	33,000 psi	228 MPa
Compression Strength CW	***	ASTM D695	12,000 psi	83 MPa
In-Plane Shear	***	Mod. D23441	5,000 psi <sup>1</sup>	34 MPa

**CW = Crosswise**      **LW = Lengthwise**

1. Follow ASTM D2344, but rotate the coupon 90 degrees (cut section of coupon length faces up)
2. Values are published as ultimate. Appropriate Safety Factors must be applied.

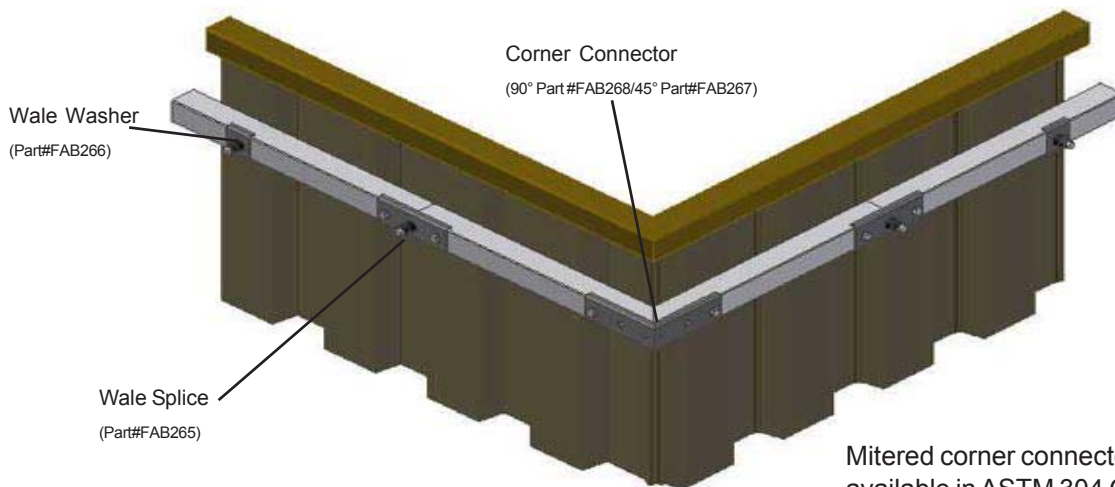

Mitered corner connectors and wale splices are available in ASTM 304 Grade Stainless Steel.  
**See Back for Load Information**

# SuperLoc™ Accessories



## SuperWale™ W-Splice

Part No.: Fab.095

Material: ASTM 240 Black Stainless Steel

Dimension: 12" L x 8.4" W (305mm x 213mm), Hole Diameter 1.125" (29 mm)

Working Load Capacity: 12,000 lbs. (5,443 kg.)

Note: Tie-rod must be backed with a 3-1/4" x 3-1/4" x 1/4" (83 mm x 83 mm x 6 mm) steel washer.

Weight: 11 lbs. (5 kg)



## SuperWale™ W-Corner Connector

Part No.: 90° Connector Fab.093

45° Connector Fab.094

Note: Special angles are available upon request; however, a 2-week lead time applies.

Material: ASTM 240 Black Stainless Steel

Dimension: Both sides 12" L x 8.4" W (304.8 mm x 213.36 mm), Hole Diameter drilled at 13/16" (20.64 mm) for a 3/4" x 4.5" (19.05 mm x 114.3 mm) bolt.

Weight: 23 lbs. (10 kg)



## SuperWale™ ASTM 240 Black Stainless Steel Washers

Part No.: 3-1/4" x 3-1/4" x 1/4" (82.55 mm x 82.55 mm x 6.35 mm) Washer Fab.096

3-1/4" x 3-1/4" x 3/8" (82.55 mm x 82.55 mm x 9.53 mm) Washer Fab.097

3-1/4" x 6" x 1/2" (82.55 mm x 152.4 mm x 12.7 mm) Washer Fab.098

Material: ASTM 240 Black Stainless Steel

Dimension: Hole diameter 1.125" (28.58 mm)

### Working Load Capacity When Used With SuperWale™

Allowable Tie-Rod Force with Specified Washers	ASTM 240 Steel	Weight
Allowable Tie-Rod Force	Steel Washer Dimensions	
4,250 lbs. (1,928 kg)	3-1/4" x 3-1/4" x 1/4" (82.55 mm x 82.55 mm x 6.35 mm)	0.75 lbs. (.34 kg)
6,700 lbs. (3,309 kg)	3-1/4" x 3-1/4" x 3/8" (82.55 mm x 82.55 mm x 9.53 mm)	1.13 lbs. (.51 kg)
11,000 lbs. (4,990 kg)	3-1/4" x 6" x 1/2" (82.55 mm x 152.4 mm x 12.7 mm)	2.75 lbs. (1.25kg)